

N I R E E E < Δ

BIKE STAND

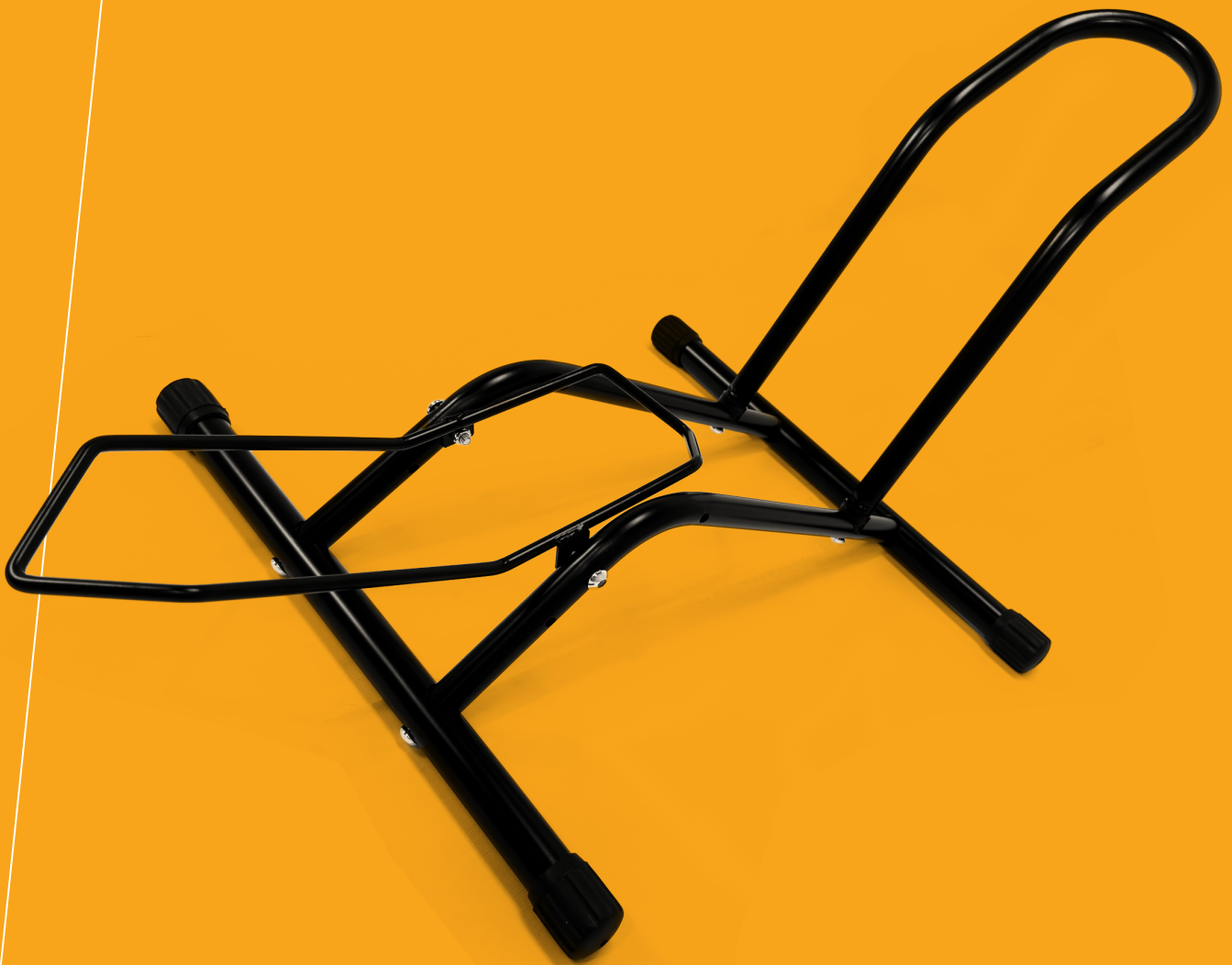

ASSEMBLY MANUAL

ORIGINAL INSTRUCTIONS

# PACKING LIST

Bracket



Transverse Tube



Bracket



Wheel Frame



Screw



Inner Six Angle  
7/16 Schaft



Solitary Gasket



## BIKE STAND ASSEMBLY

Follow the instructions to assemble it correctly:

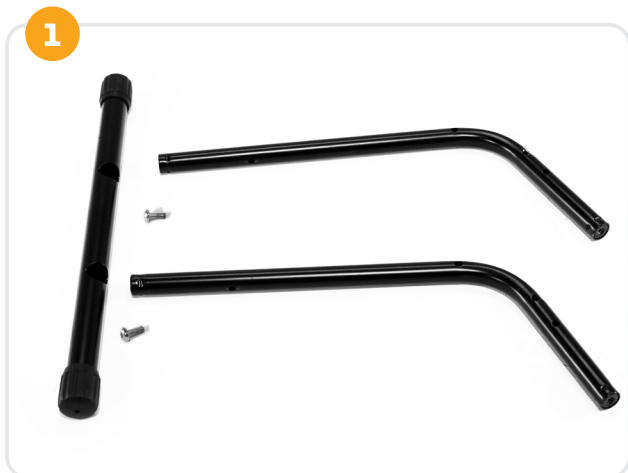

**1.** Separate a transverse tube, two brackets and two screws.



**2.** Join the two brackets to the transversal tube, inserting the two screws to join the parts.



**3.** Tighten the screw using the hexagonal wrench that comes with the set.



**4.** Attach the other transverse tube to the two brackets.

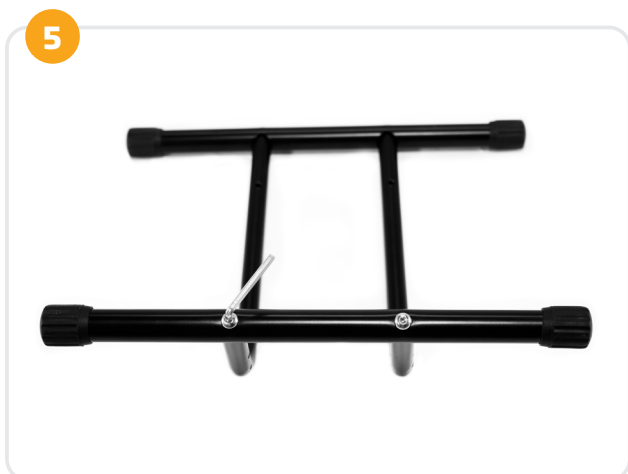

**5.** Tighten the 2 screws using the hexagonal wrench that comes with the set.

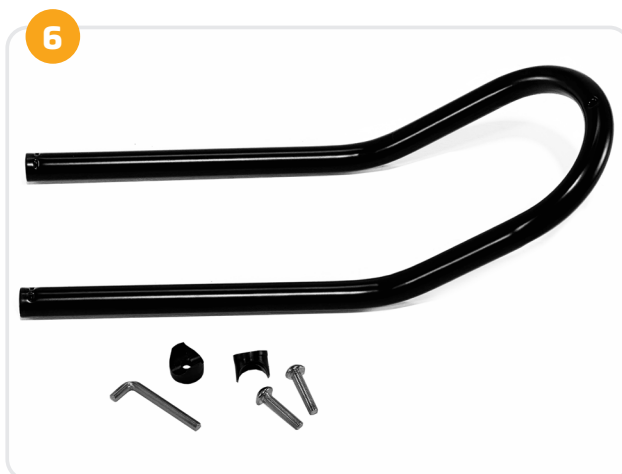

**6.** Separate the third bracket, the 2 solitary gaskets and 2 screws for the next step.

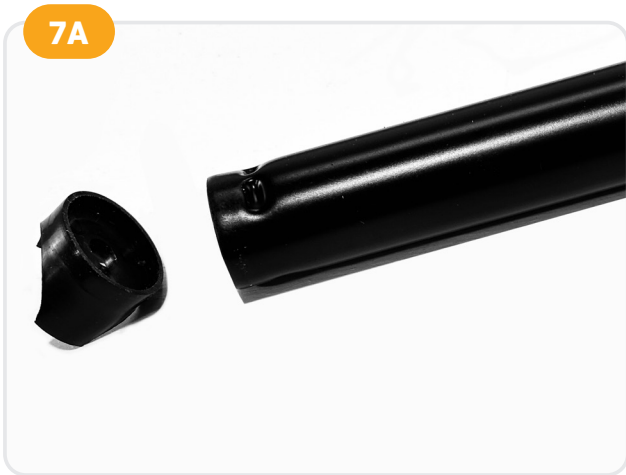

**7.** Add 1 solitaty gasket to each end of the third bracket.



**8.** Add the third bracket to the brackets attached to the transverse tube.

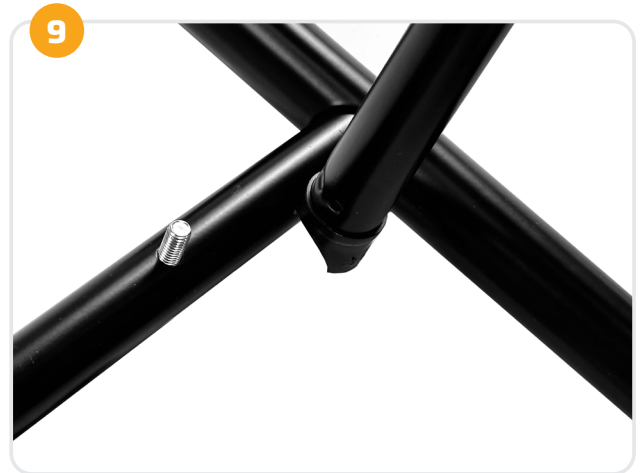

**9.** Fit the screw from the bottom up, joining the third bracket to the brackets attached to the transverse tube.

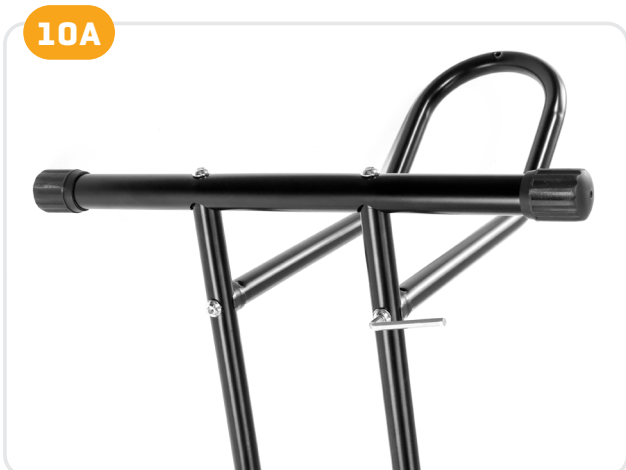

**10.** Tighten the screw, joining the third bracket to the brackets attached to the transverse tube.



**11.** Separate the wheel frame, 2 screws with nut, and hex key.

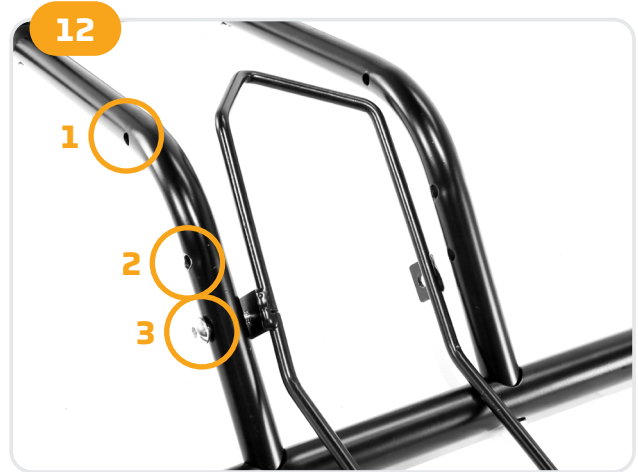

**12.** There are three holes in this model: number 1 is for tires 4" wide, number 2 is for tires 3" and number 3 is for tires 2" or smaller.

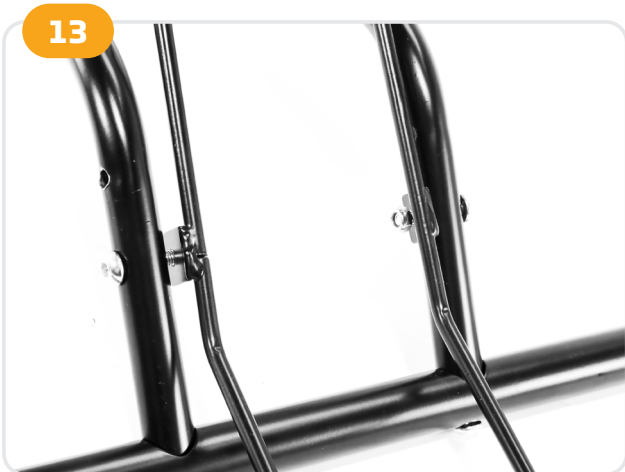

**13.** Fit the wheel frame to the 2 brackets and the bolts with nuts.



**14.** Tighten the nut screws using the open-end wrench on one side and the hexagonal wrench on the other.

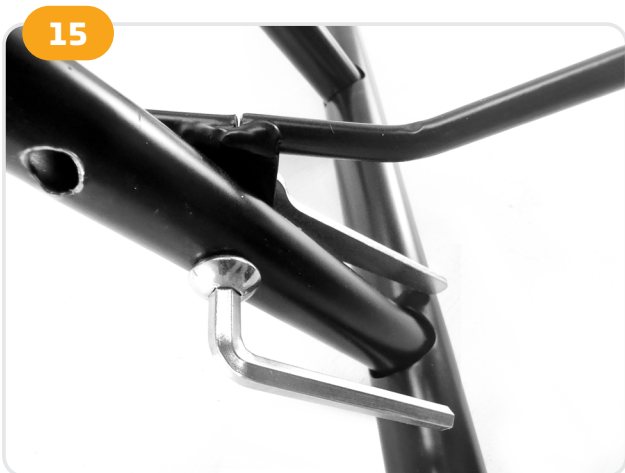

**15.** Tighten the nut screws using the open-end wrench on one side and the hexagonal wrench on the other.



**16.** The bike stand should look like this after assembly. Make sure all the screws are tight enough before use.

NIREEKA



SUPPORT

[support@nireeka.com](mailto:support@nireeka.com)  
[www.nireeka.com/help-center](http://www.nireeka.com/help-center)

[www.nireeka.com](http://www.nireeka.com)